



**IMPORTANT: Carefully read this entire Operator's Manual
before Using the Mini-Ductor® 12V**

MINI-DUCTOR® 12V

12VDC PORTABLE INDUCTION HEATING SYSTEM

OPERATOR'S MANUAL



Specializing in High Performance Induction Heating Systems

**Induction Innovations® Inc.
1175 Jansen Farm Court
Elgin, IL 60123-2595 USA
www.theINDUCTOR.com**

**Toll Free 877-688-9633
Local 847-836-6933
Fax 847-551-3369
Info@theinductor.com**

Mini-Ductor® 12V Instruction Manual Copyright 2014 by Induction Innovations® Inc.

Part # 99-500

Mini-Ductor[®] 12V Operator's Manual
Copyright 2014 by Induction Innovations[®] Inc.

All rights reserved. No part of this document shall be reproduced, stored in a retrieval system or transmitted by any means, electronic, mechanical, chemical, optical, magnetic, photocopy, printing or otherwise, except by written permission of the author or Induction Innovations[®]. No patent liability is assumed with respect to the information contained herein.

Trademarks:

Mini-Ductor[®] is a trade mark of Induction Innovations[®] Inc. Use of a trademark or service mark in this manual should not be regarded as affecting the validity of any trademark or service mark.

Warning and Disclaimer of Use:

Though every effort has been made to insure the accuracy and completeness of this manual, the information is provided with no implication of warranty or fitness. The authors and Induction Innovations[®] Inc. shall have neither liability nor responsibility to any person or entity with respect to any loss or damages, direct or indirect, arising from use of the information contained in this document.

This product is covered under these and other patents both issued and pending;
6,563,096, 6,670,590 and D 707,804

Thank you for purchasing from Induction Innovations® , Inc.

Your new Mini-Ductor® 12V has been proudly engineered and manufactured to Induction Innovation’s high standards for dependability, ease of use and operator safety. Properly cared for, this tool will provide years of rugged, trouble-free service.

For efficient service, please record the product serial number located on the product label (8) along with the information required to complete registration online at www.theinductor.com/ProductRegistration or complete the enclosed Warranty Card and mail to:

Warranty & Repair Service
Induction Innovations, Inc.
1175 Jansen Farm Court
Elgin, IL 60123-2595
www.theinductor.com

Table of Contents

	Page
I. Rules for Safe Operation	4-6
A. General Work Area Safety Rules	4
B. Personal Safety Rules	5
C. Electrical Safety Rules	6
D. Fire Hazard Safety Rules	6
E. Tool Use Safety Rules	6
II. Product Description & Contents.....	7-8
A. Mini-Ductor ® 12V and Components.....	7-8
III. Operation	9-11
A. Coil Attachments.....	9
B. Installing a Coil Attachment.....	9
C. Connecting to a 12VDC Power Supply.....	9-10
D. Using the Tool.....	10-11
IV. Cleaning the Tool.....	11
V. Special Applications	12
A. Removing Hail Damage and Dents in Sheet Metal.....	12
VI. LED & Monitoring Functions	13
VII. Trouble Shooting.....	14
VIII. How Induction Heating Works.....	14
IX. Warranty & Repairs	14
X. Training	14
XI. My Mini-Ductor® 12V	15

I. Rules for Safe Operation



The purpose of safety symbols is to attract your attention to possible dangers. The safety symbols, and the explanations with them, deserve your careful attention and understanding. The safety warnings do not by themselves eliminate any danger. The instructions or warnings they give are not substitutes for proper accident prevention measures.

SYMBOL	MEANING
	SAFETY ALERT SYMBOL: Indicates danger, warning, or caution. May be used in conjunction with other symbols or pictographs.
	DANGER: Failure to obey a safety warning will result in serious injury to yourself or to others. Always follow the safety precautions to reduce the risk of fire, electric shock, and personal injury.
	WARNING: Failure to obey a safety warning can result in serious injury to yourself or to others. Always follow the safety precautions to reduce the risk of fire, electric shock and personal injury.
	CAUTION: Failure to obey a safety warning may result in property damage or personal injury to yourself or to others. Always follow the safety precautions to reduce the risk of fire, electric shock and personal injury.
NOTE:	Advises you of information or instructions vital to the operation or maintenance of the equipment.



Comment [S1]: The 's' in the second word, "purpose" is highlight blue. I think you copy and pasted this image from another document while that letter was highlighted? No big deal if it's too difficult to change.

Comment [S2R1]: The symbols are all the same. Typically in the past these have been different symbols. Are we following international standards?

A. General Work Area Safety Rules

WARNING

- **Read and understand all instructions.** Failure to follow all instructions listed below may result in electric shock, fire, and/or serious personal injury and/or death.
- **Keep your work area clean and well illuminated.** Cluttered and dark areas invite accidents.
- **Keep children, visitors and animals away.** They may create distractions that may lead to accidents.
- **Always wear Safety Glasses.** Note that everyday eyeglasses are NOT considered safety glasses.
- **Always wear a respirator if creating fumes.** Fumes and smoke created by heating can be harmful to your health.
- **Only work outdoors if there is NO danger of rain, water or moisture.** If this is not possible, make sure that the indoor work area is well ventilated and kept free of excessive moisture.

CAUTION

- **Keep a fully charged fire extinguisher nearby at all times when using any heating device.**

B. Personal Safety Rules



- **DO NOT operate the Mini-Ductor® 12V, and stay at least twenty feet away from an operating Mini-Ductor® 12V, if you have a cardiac pacemaker or any other kind of electronic or metallic surgical implant.** Although the magnetic field emanating from the tool is effective within only a few inches, it poses a dangerous risk to the proper operation of all implanted or neighboring medical electronic devices and surgical metal implants.



- **DO NOT operate the Mini-Ductor® 12V while wearing any metallic items such as jewelry, rings, watches, chains, identification tags, religious medals, belt buckles, body piercing hardware, etc.** Induction heating devices heat metallic objects very quickly and can cause serious burns or even ignite clothing.
- **Remove all loose coins, metallic tokens, keys, chains, pocket knives, miniature tools, or any other metallic object in or on your clothing before operating the Mini-Ductor® 12V.** Induction heating devices heat metallic objects very quickly and can cause serious burns or even ignite clothing.
- **Do not wear clothing that contains metallic pocket rivets, waist band buttons, pocket buttons, zippers or other metallic features when operating the Mini-Ductor® 12V** Induction heating devices heat metallic objects very quickly and can cause serious burns or even ignite clothing.
- **Always wear safety glasses or goggles when using the Mini-Ductor® 12V.**
- **Always wear a dual filter (dust and fume) respirator mask certified by the Occupational Safety and Health Administration (OSHA), the National Institute of Safety and Health (NIOSH), or the United States Bureau of Mines since fumes created from heating objects may emit toxic vapors.** These masks and replaceable filters are readily available at major hardware stores. Be sure the mask fits as beards and facial hair may keep masks from sealing properly. Change filters often. DISPOSABLE PAPER MASKS ARE NOT ADEQUATE.
- **Wear heat-resistant gloves.** The Mini-Ductor® 12V heats metal very quickly and you may burn your hands and fingers when trying to manually remove parts from hot metal surfaces.
- **Do not operate the Mini-Ductor® 12V while under the influence of drugs, alcohol or any medication.**
- **Do not overreach and maintain proper footing and balance at all times.** Proper footing and balance enables better control of hand tools during unexpected situations.
- **For automotive applications, DO NOT use the Mini-Ductor® 12V within 4 inches of any airbag component.** The heat created during induction heating can ignite the air bag propellant causing it to deploy without warning. The induced current can also activate the sensors of an airbag if placed near its wire. Refer to the vehicles service manual for the precise airbag location before operating the Mini-Ductor® 12V.

C. Electrical Safety Rules

DANGER

- **Do not use in rain, excessive moisture or immerse in water.** Exposing the Mini-Ductor® 12V to water or other liquids may cause an electrical shock hazard.

WARNING

- **Do not abuse the electrical cord.** Never use the cord to carry the Mini-Ductor® 12V. Keep all electrical cords away from heat, oil, sharp edges and/or moving parts. Do not use the Mini-Ductor® 12V if any cord is damaged. Damaged electrical cords cannot be repaired, they must be replaced.

CAUTION

- **Disconnect the Mini-Ductor® 12V from the power source when not in use and before removing or changing coils.**

D. Fire Hazard Safety Rules

DANGER



- **Do not attempt to heat aerosol cans, paint cans, or any pressurized containers used for storing fuels, compressed gases, and liquids.** The heat generated by the Mini-Ductor® 12V can cause these containers to explode and their contents to ignite.

CAUTION

- **Do not use any work coil if its insulation has been breached.** If coil insulation has been breached, the exposed coil can cause sparking when contacting a vehicle component. This can create a fire hazard especially when working on or near gas lines and/or gas tanks.

E. Tool Use and Maintenance Safety Rules

WARNING

- **Do not leave the Mini-Ductor® 12V unattended when connected to the power source.**
- **Make sure that the Mini-Ductor® 12V has a sufficient supply of fresh air for cooling.** Keep the vents of the Mini-Ductor® 12V clean and free of dust and debris so that the tool has an unimpeded continuous flow of cooling air.

CAUTION

- **Do not attempt to repair or service the Mini-Ductor® 12V tool.** Any repairs requiring disassembly must be performed only by Inductive Innovations, Inc. authorized service center. There are no user-serviceable parts inside the tool.
- **Do not use the Mini-Ductor® 12V longer than the allowed duty cycle.** The Mini-Ductor® 12V unit has an overheat protection circuit. However the coil electrode attachments do not have overheat protection and may overheat damaging the coil insulation. The recommended duty cycle for the unit is two minutes on and two minutes off.

II. Product Description & Contents

The Mini-Ductor® 12V portable kits give you everything you need to operate the Mini-Ductor® 12V induction heating tool in remote locations where access to 120 VAC is not possible. The Mini-Ductor® 12V provided in this kit has been specifically engineered to provide similar results from a 12 VDC power supply (using the portable battery pack or a 12VDC car battery using the battery extension cable) as induction heating tools operating at 120 VAC. This portability feature makes the Mini-Ductor® 12V portable power supply line of products a great choice for emergency repairs, remote locations and controlled environments.

Mini-Ductor® 12V with 2ft Battery Hook-up Clamps

Portable induction heating system

Qty	P/N	Description
1	MD-500	Induction Heating Kit (see section III)
1	V12-2	2 ft Direct-to-Battery Extension Cable

Mini-Ductor® 12V with V12-20 Battery Pack Power Supply

Portable induction heating system for 20 minutes of use per charge

Qty	P/N	Description
1	MD-500	Induction Heating Kit (see section III)
1	V12-20	12VDC Battery Pack Power Supply (20 minutes of use per charge)

Optional Accessories



Qty	P/N	Description
1	V12-12	12 ft Direct-to-Battery Extension Cable
1	V12-2	2 ft Direct-to-Battery Extension Cable
1	V12-20	12VDC Battery Pack Power Supply (20 minutes of use per charge)
1	V12-60	12VDC Battery Pack Power Supply (60 minutes of use per charge)

Mini-Ductor® 12V

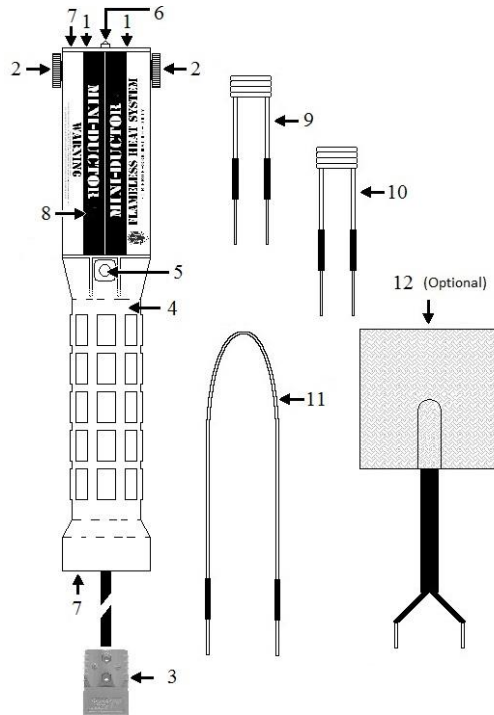
1. Coil Attachment Ports (top)
2. Thumb Screws
3. 8 FT Cable w/12VDC Plug
4. Sure Grip Plastic Handle
5. Power Actuator
6. LED work light
7. Air Vents (both ends)
8. Product Info Label
9. Preformed Coil Attachment 7/8" DIA
10. Preformed Coil Attachment 1" DIA
11. U-Form Coil
12. Mini-Pad Attachment (optional)
13. Storage case (Not Shown)
14. Owner's Manual (Not Shown)



Available Power Supplies

V12-20 Portable Battery Pack Power Supply	V12-60 Portable Battery Pack Power Supply
	
<ul style="list-style-type: none"> • Designed to provide the Mini-Ductor® 12V with 20 minutes of use per charge • 1700 Peak Amps • 46" #2 AWG welding cable leads w/Industrial-grade clamps • Built-in automatic charger • Voltmeter provides charge status of onboard battery • 12VDC outlet to power accessories • 1 year limited warranty 	<ul style="list-style-type: none"> • Designed to provide the Mini-Ductor® 12V with 60 minutes of use per charge • 2000 Peak Amps • 46" #2 AWG welding cable leads w/Industrial-grade clamps • Built-in automatic charger • Voltmeter provides charge status of onboard battery • 12VDC outlet to power accessories • 1 year limited warranty

III. Operation

A. Coil Attachments

The Coil Attachments (9, 10, 11, 12) transmit the energy from the tool to the ferrous part that needs to be heated. The Mini-Ductor® 12V comes with three basic coil configurations that can be used to heat nuts, fasteners, free frozen door hinges, loosen exhaust manifold bolts, truck under bed bolts, O₂ Sensors, etc.

- a) A preformed coil with a 7/8" diameter loop to fit over objects less than 3/4".
- b) A preformed coil with a 1" diameter loop to fit over objects less than 7/8".
- c) A U-Form coil that can be custom formed to fit around many different shapes. This coil can be configured to various nut sizes by simply wrapping it around a socket sized for that nut. Note that the more coil winds you can get (with a minimum of two winds), the faster it will heat the nut.

There is also an optional Mini-Pad Coil attachment available that provides energy across a large flat surface for heating large areas, softening adhesive to remove labels, removing moldings etc.

B. Installing a Coil Attachment

- a) Slightly loosen the Thumb Screws (2)
- b) Insert the two legs of a Coil Attachment into the Coil Attachment Ports (1)
- c) Securely tighten the Thumb Screws (2) and ensure that the Coil Attachment is held firmly in place.

⚠ WARNING

The Coil Attachment **MUST** be firmly engaged by thoroughly tightening the Thumb Screws (2). A loose Coil Attachment may cause arcing which will damage the tool.

C. Connecting to a 12VDC Power Supply

A. Connecting to an automotive 12VDC car battery:

⚠ DANGER

- Always wear safety glasses when working on or near automotive batteries.
- Do not smoke or use an open flame when attaching cables to a battery.

- a) Connect the provided 2 foot battery extension cable (V12-2) to your Mini-Ductor® 12V by aligning the gray connectors and pressing together so they are firmly seated together.

- b) Attach the red (positive +) clamp of the 2 foot battery extension cable to the positive terminal of the 12VDC car battery. Make sure the clamp is securely attached to the battery terminal. Note that on some vehicles, you may have to remove a plastic cover from the positive battery terminal before you can make this connection.
- c) Attach the black (negative -) clamp of the 2 foot battery extension cable to the negative terminal of the 12VDC car battery.
- d) Your Mini-Ductor® 12V induction heating tool is now powered and ready for use.

B. Connecting to a 12VDC portable battery power supply (V12-20 or V12-60) Read and understand the Instruction Manuals for these products.

- a) The V12-20 and V12-60 12VDC portable power supplies are originally shipped in a low charge condition. Therefore, the power supplies should be charged for at least 6 hours prior to the first use. After that, the power supplies can be kept on a continuous trickle charge using the provided charging cord.
- b) The V12-20 and V12-60 12VDC portable power supplies come equipped with a connector that mates directly with the connector on Mini-Ductor® 12V.
- c) Simply align the gray connector on the power supply to the connector on your Mini-Ductor® 12V and press together until they are firmly seated.
- d) Your Mini-Ductor® 12V induction heating tool is now powered and ready to use.

D. Using the Tool

⚠ WARNING

The Coil Attachment **MUST** be firmly engaged by thoroughly tightening the Thumb Screws (2). A loose Coil Attachment may cause arcing which may damage the tool.

- a) Make sure that the Coil Attachment is held firmly in place by tightening the Thumb Screws (2).
- b) Push the Power Actuator switch (5) to send energy to the installed Coil Attachment. The LED (6) work light will also light when the switch is pushed. Note: the Power Actuator is a momentary type switch so the unit will remain ON only as long as pressure is applied to the Power Actuator switch.
- c) Place the Coil Attachment around the frozen nut (or ferrous part) to be heated, for only **TWO SECONDS**, then back the Coil Attachment away and try to remove the nut (or part) with a wrench or socket. If it is still frozen, apply the Coil Attachment for another **TWO SECONDS** and try the wrench again.

Though it is sometimes cool to watch, there is usually no reason to heat a nut to a red-hot condition in order to loosen it. In fact, heating a nut to a red-hot condition will shorten the life of the Coil Attachment and may change the molecular structure of the metal, thus changing the parts integral design.

- d) NOTE: The Mini-Ductor® 12V has built-in thermal overload protection and may shut itself off if it is used beyond its recommended duty cycle of 2 minutes ON followed by 2 minutes OFF. If the tool does shut itself down, allow it to cool for approximately 30 minutes before using the tool again.
- e) Whenever the tool is used, ALWAYS make sure that the Thumb Screws (2) are tight.
- f) When finished using the tool, release the Power Actuator switch (5) and allow the tool and the Coil Attachment to cool for at least 30 minutes before removing the coil and cleaning and storing the tool.

Comment [LSE3]: 30 minutes seems too long?

⚠ CAUTION

Handling or storing of the tool or Coil Attachment before they have cooled may result in personal injury, damage to the tool and may pose a fire hazard.

- g) The cooling fan will operate at Low Speed whenever the tool is plugged into a 12VDC Power Source and will operate at Full Speed whenever the Power Actuator switch is pressed.
- h) Once the tool is cooled, place the tool and coil attachments into the storage case and store in a safe place.

IV. Cleaning the Tool

- a) Make sure unit is off and unplugged from the Power Supply.
- b) Use a clean, non-abrasive cloth or paper towel dampened with a suitable nonflammable cleaning solvent to remove any grease, oil, and other contaminant from the inverter, coils, and electrical cords before returning them to the storage case.
- c) Allow all components to dry completely before storing or using the Mini-Ductor II ® 12V.
- d) Do NOT immerse any components of the unit in water or a cleaning solution.
- e) Do NOT spray the unit with a stream of water from a hose, or wash any parts under a stream of water from a faucet, hydrant or shower.
- f) Do NOT clean any components with volatile organic compounds such as gasoline, benzene, kerosene, methyl ethyl ketone (MEK), fuel oil, brake part cleaners, paint remover and thinners, varnish removers, plastic adhesive solvents, etc. These substances are fire hazards and will harden or dissolve the polymer materials used in the Mini-Ductor II® 12V components.

- g) Do NOT use heat guns, space heaters, torches, microwave or gas ovens, etc. to dry the components of the Mini-Ductor II® 12V after cleaning.

V. Special Applications

Comment [LSE4]: not recommended for this application

A. Using the Mini-Ductor® 12V to Remove Hail Damage or Soft Dents in Sheet Metal

- a) Configure the U-Form Coil to look like FIG. 1 below.
- b) Install the U-Form Coil Attachment and ready the Mini-Ductor® 12V as outlined in Steps 1 to 3 above.
- c) Hold the formed U-Form Coil 1/4 inch above the dent and move it in small circular motions around the outside edges of the dent gradually bringing it closer to the surface of the dent. As soon as the dent begins to shrink, remove the U-Form Coil and cool the treated dent with a damp rag. If the dent becomes worse, you are heating the area too close to the crown and not far enough around the outside of the crown. Repeat the procedure until removed completely. Heating around the outside of the crown of the dent will heat shrink the dent inward.
- d) Note 1: If a puff of smoke releases from the dent, immediately remove the U-Form Coil from the area as this may indicate that the metal has become too hot and paint may begin to burn, discolor, or bubble.
- e) Note 2: Be careful heating white and light- colored finishes as these lighter colors tend to yellow sooner than darker colors.
- f) Note 3: If the dent doesn't shrink or disappear, the metal may have been creased or been stretched too far.

Or the metal of the vehicle is non-ferrous, such as aluminum. Aluminum has no metal memory and will not heat shrink alone. It will also require massaging the dent out with other tools. Some metals are alloys of non-ferrous metals and may pose a similar or same failed attempts. Paintless dent repair with the Mini-Ductor is best

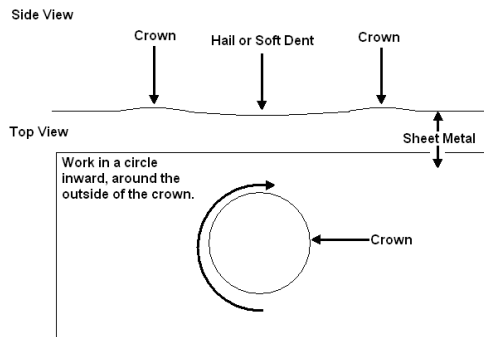

performed on ferrous metals.



FIG. 1

VI. LED & Monitoring Functions

The Mini-Ductor II® 12V is designed to operate with a nominal voltage of 12 VDC. It has over voltage lockout that disables operation when the voltage applied is greater than approximately 16 VDC. It can be operated from an automotive battery with the vehicle running as it is protected from transients and load dumps that may occur from the vehicle charging systems. The typical voltage under this condition is 13.5 VDC. The tool will not operate on a 24 volt system.

To prevent battery damage, the Mini-Ductor II® 12V has an under voltage shut down at approximately 10 VDC. Discharging a battery below this voltage may degrade the performance of the battery. Reverse battery connection can be tolerated, without damage to the tool. The Mini-Ductor II® 12V will not operate with a reversed power connection. The fan and tool can not operate with reversed polarity.

The Mini-Ductor II® 12V fan will operate as long as it is attached to a power source in the correct polarity. The low speed fan operation is an indication of power.

Depressing the Actuator switch will illuminate the white LED lamp, apply full power to the fan increasing the air flow for internal cooling and supply power to the circuitry that produces the high frequency, high current, low voltage to the work coil.

There is circuitry to detect fault conditions in the tool.

The white LED lamp will blink On and Off for the following conditions as long as the power actuation switch is depressed:

1. Over current - If the tool draws more than 70 amps from the power source. A shorted work coil or using the U-Form Coil with too many turns around an object may cause this condition.
2. Over temperature - If the internal electronics get too hot.
3. Short cycling - The tool will respond to rapidly depressing and releasing the power actuation switch as a fault or an intermittent connection to the power source. Circuitry provides current limitations on start. Intermittent conditions are detected as a fault.

There is also a second thermal limit switch that if the power on duty cycle is exceeded may trip. The fan will continue to run, but the tool will not operate until the thermal switch resets. This may take 5 to 10 minutes.

VII. Trouble-Shooting

A. If the Mini-Ductor® 12V tool will not heat the work surface:

- a) Make sure that the tool is properly connected to a functioning (fully charged) 12VDC Power Source.
- b) If the tool was recently used, make sure it did not exceed its duty cycle of 2 minutes ON followed by 2 minutes OFF. Let the tool cool for 30 minutes before re-using it.
- c) Make sure all cables are intact.
- d) Contact Induction Innovations, Inc. at 877-688-9633

B. The Coil Attachment arcs when heating the work surface:

- a) The Coil Attachment is not properly inserted or secured in the port or has an insulation breach in the work coil. Always tighten the Thumb Screws (2) before every use and replace any damaged coils.

VIII. How Induction Heating Works

The specially-designed electronics in the Mini-Ductor® 12V produce a high current output that is converted by the installed Coil Attachment to a high frequency alternating magnetic field. This magnetic field enters the conductive metallic work surface (a frozen nut for example) and vibrates the electrons in the metal through a principle called electromagnetic induction. The friction of the moving electrons creates heat, which warms whatever metal is within the tool's working range. The more easily a substance can be magnetized (ferrous), the faster it will heat. That is why the Mini-Ductor® 12V heats ferrous metals and alloys quite readily, but has no effect on glass, plastics, wood, cloth and other non-conductive materials.

Comment [LSE5]: through inductive coupling creates eddy currents to flow within the ferrous object in the work coil field.

IX. Warranty & Repairs

A. LIMITED WARRANTY

Induction Innovations Inc. warrants the Mini-Ductor® 12V and any parts thereof, to be free from defects in materials and workmanship for one year from the date of initial purchase, excluding all Coil Attachments, when operated in accordance with this *Operator's Manual*. This warranty is extended to the original purchaser only if accompanied by the original proof of purchase. Induction Innovations Inc. will pay for any ground transportation costs when returning a unit repaired under warranty to a customer within the United States. This warranty covers only the cost of parts and labor to restore the product to a proper operating condition. Transportation and other incidental costs not specifically identified in this warranty statement are not reimbursable. Warranty service is available only through Induction Innovations Inc. This warranty does not cover defects resulting from misuse, abuse, negligence, accidents, normal wear, alteration, modification, tampering, or repair by anyone other than the manufacturer. This express warranty is given in lieu of any other warranty either expressed or implied, including warranties of merchantability and fitness for a particular use. Induction Innovations Inc. assumes no responsibility for indirect, incidental or consequential damages. Some states do not allow the exclusion or limitations of incidental or consequential damages or limitations or exclusions may not apply to you. This Limited Warranty gives you specific legal rights and you may also have other rights which vary from state to state. Warranty is not valid unless the warranty card is returned within 30 days of the date of purchase. No unit will be warranted without proof of purchase. Shipping to Inductive Innovations will be at the consumer's own expense. Return shipping will be at the factory's expense for units repaired under warranty. Return shipping will be via ground, unless the consumer wishes to pay for faster service. Induction Innovations Incorporated is not responsible for lost, stolen, or damaged unit(s) due to shipping. Warranty is non-transferable. When returning an Inductor® Mini-Ductor® 12V, all coil attachments and accessories must be returned with the unit to qualify for warranty repair. Call 877-688-9633 for return authorization prior to shipment.

Comment [LSE6]: What about online registration?

Warranty & Repair Service
Induction Innovations, Inc.
1175 Jansen Farm Court
Elgin, IL 60123-2595

X. Training

A. Additional Training on the use of the Mini-Ductor® 12V is available online through I-CAR:

1. Induction Heaters (INH01)



XI. My Mini-Ductor® 12V

My Dealer: _____

My Name: _____

My Address: _____

City _____ State ____ Zip _____

My Phone #: _____

Alt. Phone #: _____

Fax #: _____

My Email: _____

Website: _____

Model: Mini-Ductor® 12V

Serial #: _____

Please complete and send to:

**Warranty & Repair Service
Induction Innovations, Inc.
1175 Jansen Farm Court
Elgin, IL 60123-2595**

**You may also register online at:
www.theinductor.com/ProductRegistration**

Notes: