



IMPORTANT: Read These Operating and Safety Instructions before Using the Mini-Ductor® Venom® and Venom® HP

MINI-DUCTOR® VENOM® and VENOM® HP

OPERATING AND SAFETY INSTRUCTIONS

**Specializing in High Performance Induction Heating
Systems for the Automotive Aftermarket**



INDUCTION INNOVATIONS

**Induction Innovations®, Inc.
1175 Jansen Farm Court
Elgin, IL 60123-2595
www.theINDUCTOR.com**

**Toll Free 877-688-9633
Local 847-836-6933
Fax 847-551-3369
Info@theinductor.com**

Mini-Ductor® Venom® and Venom® HP Instruction Manual
Copyright © 2022 by Induction Innovations®, Inc.

All rights reserved. No part of this document shall be reproduced, stored in a retrieval system, or transmitted by any means, electronic, mechanical, chemical, optical, magnetic, photocopy, printing or otherwise, except by written permission of the author or Induction Innovations®. No patent liability is assumed with respect to the information contained herein.

Trademarks

Mini-Ductor® Venom® and Venom® HP is a trademark of Induction Innovations®, Inc. All terms or service marks used in this manual have been appropriately capitalized. The company, Induction Innovations® Incorporated, can not attest to the accuracy of this information. Use of a trademark or service mark in this manual should not be regarded as affecting the validity of any trademark or service mark.

Warning and Disclaimer of Use:

Every effort has been made to ensure the accuracy and completeness of this manual, but no warranty or fitness is implied. This information is provided on an as is bases. The authors and Induction Innovations®, Inc. shall have neither liability nor responsibility to any person or entity with respect to any loss or damages, direct or indirect, arising from use of the information contained in this document.

Table of Contents

		Page
I.	Safety Rules.....	4-7
	A. General Work Area Safety Rules.....	4
	B. Personal Safety Rules	4-5
	C. Electrical Safety Rules.....	6
	D. Fire Hazard Safety Rules	7
	E. Tool Use Safety Rules	7
II.	Components.....	8
	A. Mini-Ductor® Venom® and Venom® HP Components ■ ■ ■ ■	8
III.	Principles of Operation	9
IV.	Preparation for Use.....	9
	A. Generator & Inverter Use ■ ■ ■ ■ ■ ■ ■ ■ ■ ■ ■ ■ ■ ■ ■ ■	9
	Generator	9
	Inverter	9
V.	Using the Preformed Coil.....	10
	A. Loosening Corroded, Rusted and “Frozen” Nuts and Bolts $\leq 3/4$ ”	10
VI.	Using the U-Form Coil.....	10-11
	A. Loosening Corroded, Rusted and “Frozen” Nuts and Bolts $> 3/4$ ” ..	10
	B. Heat Shrinking Hail / Soft Dents in Sheet Metal.....	10-11
VII.	Using the Bearing Buddy® Coil	11
	A. Expanding a piece to remove an interlocking part.....	11
VIII.	Using the Mini-Pad (optional).....	11
	A. Removing Bonded on parts.....	11
IX.	Troubleshooting.....	11-12
X.	Disassembly & Storage	12
XI.	Cleaning Instructions.....	12
	A. Proper Cleaning Care	12
	B. Improper Cleaning Care.....	12
XII.	Warranty & Repairs.....	13
	A. Limited Warranty	13
XIII.	Definitions	14-15
XIV.	Additional Training	15
XV.	My Mini-Ductor® Venom® and Venom® HP Dealer Information.....	16

This product is covered by patent numbers; 6,563,096 and 6,670,590

I. Safety Rules for Using the Mini-Ductor® Venom® and Venom® HP

A. General Work Area Safety Rules



Read and understand all instructions. Failure to follow all instructions listed below may result in electric shock, fire, and/or serious personal injury.



Keep your work area clean and well illuminated. Cluttered and dark areas invite accidents.



Keep bystanders, children, visitors, and animals away while operating the Mini-Ductor® Venom® or Venom® HP. These beings may create distractions that cause you to lose control of the Mini-Ductor® Venom® or Venom® HP.



Work outdoors if there is no danger of rain, water, or moisture. If this is not possible, keep the inside work area well ventilated and dry. Be sure that ventilation fans are moving air from the inside to the outside.



Keep a fully charged fire extinguisher at hand at all times when using the Mini-Ductor® Venom® or Venom® HP.

B. Personal Safety Rules



Do not operate the Mini-Ductor® Venom® or Venom® HP and stay at least three feet away from an operating Mini-Ductor® Venom® or Venom® HP, if you have a cardiac pacemaker or any other kind of electronic or metal surgical implant. Although the magnetic fields emanating from the tools travel only a few inches, they pose a dangerous risk to the proper operation of all implanted medical electronic devices in the user and any bystanders. Thus, it is necessary that people with electronic or metallic medical implants do NOT use the Mini-Ductor® Venom® or Venom® HP or come within three feet of it when it is in use in case an accident should occur and the tool in use is inadvertently and unexpectedly brought near the person with the implant.



Do not operate the Mini-Ductor® Venom® or Venom® HP while wearing any metallic items such as jewelry, rings, watches, chains, identification tags, religious medals, belt buckles, body piercing hardware, etc. The Mini-Ductor® Venom® or Venom® HP can heat these metallic objects very quickly and cause serious burns or even ignite clothing.



Do not operate the Mini-Ductor® Venom® or Venom® HP while under the influence of drugs, alcohol, or any medication.



Do not overreach, keep proper footing and balance at all times. Proper footing and balance enable better control of the Mini-Ductor® Venom® or Venom® HP in unexpected situations.



Do not use the Mini-Ductor® Venom® or Venom® HP within 4 inches of any airbag component. The heat created from the Mini-Ductor® Venom® or Venom® HP can ignite the air bag propellant,

causing it to explode without warning. Refer to the vehicles service manual for precise airbag location before operating.

⚠ WARNING



Remove all loose coins, metallic tokens, keys, chains, pocketknives, miniature tools, or any other metallic object in or on your clothing before operating the Mini-Ductor® Venom® or Venom® HP. Do not replace these items until you are finished using the Mini-Ductor® Venom® or Venom® HP. The Mini-Ductor® Venom® or Venom® HP can heat these metallic objects very quickly and cause serious burns or even ignite clothing.

⚠ WARNING



Do not wear clothing that is made with metallic pocket rivets, waist band buttons, pocket buttons, and zippers when operating the Mini-Ductor® Venom® or Venom® HP. The Mini-Ductor® Venom® or Venom® HP can heat such metallic items very quickly and cause serious burns or even ignite clothing.

⚠ WARNING



Always wear safety goggles when using the Mini-Ductor® Venom® or Venom® HP.

⚠ WARNING



Fumes and smoke from hot/burning adhesives are toxic. Wear a dual filter (dust and fume) respirator mask which has been approved by the Occupational Safety and Health Administration (OSHA), the National Institute of Safety and Health (NIOSH), or the United States Bureau of Mines. These masks and replaceable filters are readily available at major hardware stores. Be sure the mask fits. Beards and facial hair may keep masks from sealing properly. Change filters often. **DISPOSABLE PAPER MASKS ARE NOT ADEQUATE.**

⚠ WARNING



Wear heat-resistant gloves when using the Mini-Ductor® Venom® or Venom® HP. The Mini-Ductor® Venom® or Venom® HP heats metal very quickly. You can burn your hands and fingers when trying to remove parts from hot metal surfaces.

C. Electrical Safety Rules

⚠ DANGER



Do not use the Mini-Ductor® Venom® or Venom® HP in the rain, moisture or immerse in water. Exposing the Mini-Ductor® Venom® or Venom® HP to water or other liquids may cause an electrical shock hazard.

⚠ WARNING



Do not abuse the electrical cord. Never use the cord to carry the Mini-Ductor® Venom® or Venom® HP. Keep the cord away from heat, oil, sharp edges and/or moving parts. Do not use the Mini-Ductor® Venom® or Venom® HP if the cord is damaged. Cords cannot be repaired, only replaced. Damaged cords create electric shock hazards.

⚠ WARNING



Disconnect the Mini-Ductor® Venom® or Venom® HP power supply cord from the outlet before changing any of the applicators.

⚠ CAUTION

Unplug the Mini-Ductor® Venom® or Venom® HP from the power supply outlet or cord when not in use.

⚠ CAUTION



EXTENSION CORDS:

If an extension cord is necessary, only the following two cord lengths are authorized for use with the Mini-Ductor® Venom® or Venom® HP:

25-ft, 14-AWG.

50-ft, 12-AWG.

- Use only one extension cord at any one time.
- Do not connect two or more extension cords in series with each other.
- Do not use any other extension cords except those specified above. Unwrap extension cords — tightly wrapped extension cords can overheat and cause fires.

D. Fire Hazard Safety Rules

⚠ DANGER



Do not attempt to heat aerosol cans, paint cans, or any pressurized containers used for storing fuels, compressed gases, and liquids. The heat generated by the Mini-Ductor® Venom® or Venom® HP can cause these containers to explode and their contents to ignite.

⚠ CAUTION



Do not use any heating coil if insulation has been breached. If insulation has been breached it will cause sparking when contacting with a vehicle. This will be a fire hazard especially when working on or near gas lines and/or gas tanks.

E. Tool Use Safety Rules

⚠ WARNING



Do not leave the Mini-Ductor® Venom® or Venom® HP unattended when it is ON.

⚠ WARNING



Make sure that the Power Unit has a sufficient supply of air for cooling. Make sure that the vents of the Mini-Ductor® Venom® or Venom® HP Power Unit are clean and free of dust and debris so that the Power Unit has an unimpeded flow of cooling air.

⚠ CAUTION

Do not attempt to repair or service the Mini-Ductor® Venom® or Venom® HP. There are no user-serviceable parts except for replacing the coil attachments.

⚠ CAUTION

Before plugging in the Mini-Ductor® Venom® or Venom® HP, make sure that the outlet voltage supplied is compatible with the voltage marked on the nameplate within 10%. An outlet voltage incompatible with that specified on the nameplate can result in serious hazards and damage to the Mini-Ductor® Venom® or Venom® HP.

⚠ CAUTION

Do not twist or bend electrical cord sharply, or damage to internal wiring may result.

⚠ CAUTION

Do not use the Mini-Ductor® Venom® or Venom® HP longer than the duty cycle. The circuit board has an overheat protection device for protection, however the **electrodes** (10) do not have overheat protection. Duty cycle: two minutes on two minutes off.

II. Components

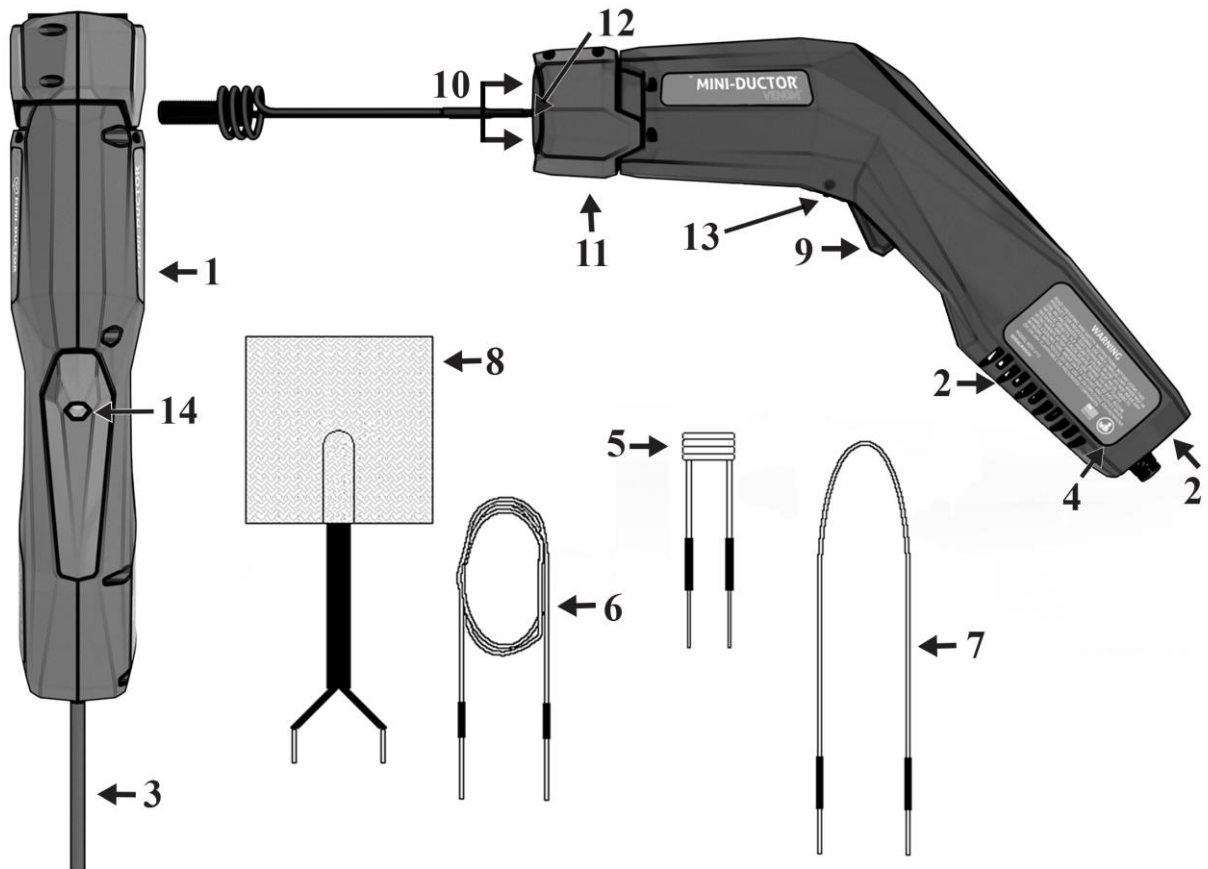

1. Inverter
2. Vent
3. Cord 110/120 AC
4. Serial Plate/Model
5. Preformed work coil
6. Bearing Buddy® work coil
7. U-Form work coil

8. Mini-Pad work coil (optional)
9. Activation Switch
10. Electrodes (top)
11. Twist-Lock
12. Illumination LED
13. Illumination LED Switch
14. Status Indicator LED

III. PRINCIPLES OF OPERATION

The **power cord** (3) should be plugged into a GFI protected outlet that provides 120 VAC - 60 Hz. The tool can draw up to 10 amps during operation.

Inside the tool is a power supply and inverter that converts the AC line voltage to a high frequency output for induction heating of ferrous materials.

The tool accommodates several accessories for different applications. They include work coils of various lengths, diameters, and configurations.

There are **Preformed Coils** (5), **U-Form Coils** (7), **Bearing Buddy® Coils** (6) or a **Mini-Pad** (8) that can be attached to the tool by inserting into the end of tool and then secured to the electrodes using the **Twist-Lock** (11).

Pressing the **activation switch** (9) will activate the inverter operating the tool. A **status indicator LED** (14) illuminates GREEN to designate proper operation.

The **status indicator LED** (14) will illuminate RED if the work coil is not properly installed or broken. It will also indicate an over temperature condition in the tool when lit RED.

The work coil operates by electromagnetically coupling energy to the object in the field of the coil. This energy heats any metal by eddy currents (also called Foucault currents).

There is also heating by the action of magnetic hysteresis losses of a ferrous material. The more easily a material is magnetized, the more effective the tool is for heating.

The Mini-Ductor® Venom® and Venom® HP heat ferrous materials and their alloys readily, but have no effect on glass, plastic, wood, cloth, and any other non-conductive material.

The Mini-Ductor® Venom® and Venom® HP have an **illumination LED** (12) activated by a **slide switch** (13) located just above the **activation switch** (9).

The **activation switch** (9) activates the inverter when actuated and operates independently from the **slide switch** (14).

There is a fan that operates to cool the electronics in the tool. The fan will continue to operate after the activation switch is released until it cools down.

Record the serial number from the **serial plate** (4) on the inverter to the enclosed Warranty Card and mail or register on www.theinductor.com.

IV. PREPARATION FOR USE

WARNING



Read and understand all safety warnings and cautions in this manual before operating the Mini-Ductor® Venom® and Venom® HP.

A. Generator & Inverter Use

CAUTION

The Mini-Ductor® Venom® and Venom® HP are designed to operate from a normal 120 volt alternating current (VAC), 50 or 60 Hz (cycles per second) power line or service outlet, and will operate without suffering damage on voltages up to 130 VAC.

1. Generator: Some portable generators, particularly low-cost units producing 4 kW or less, are unregulated and can produce in excess of 140 VAC which will damage the unit and void the warranty. If you are in doubt concerning the electrical generator that will be supplying power to the Mini-Ductor® Venom® and Venom® HP, have a professional electrical contractor measure the generator voltage with a digital voltmeter. Measure the voltage with the generator engine warm and no load. In some generators, the voltage may be reduced by decreasing the engine speed.
2. Inverter: DC to AC Inverter operation; Use only 1.8 kW (Prosine™1800 is recommended) or larger sine wave inverter. The use of square or quasi-sine wave inverter will void the warranty. Call Induction Innovations®, Inc. at 877-688-9633, before using your Mini-Ductor® Venom®

and Venom® HP for instructions on how to proceed if you have any questions regarding the instructions furnished above.

V. Using the Preformed Coil

Function: The **Preformed Coil** (5) is used to heat nuts, fasteners, frozen door hinges, exhaust manifold bolts, truck under bed bolts, Sensors (O²), coatings from hardware, ... etc....



The life of the work coils can be extended by heating objects enough only to loosen them. Heating objects to red hot will shorten the life of the work coil and its insulation.

Choose a coil that fits loosely leaving a small gap between the work coil and workload. This will reduce abrasion on the insulation and extend the life of your work coil.

A. Loosening Corroded, Rusted and “Frozen” Nuts and Bolts $\leq 3/4$ ”

Step 1 Perform the “Preparation for Use” instructions.

Step 2 Push the activation switch to activate the Mini-Ductor® Venom® and Venom® HP.

Step 3 Bring the Preformed Coil around the frozen nut, initially for only six seconds if using the Venom® or three seconds if using the Venom® HP, back it away, and try to remove the nut with a wrench or socket. If it is still seized, repeat the procedure, and then try loosening with the wrench or socket again. There is usually no reason to heat to a red-hot condition to release it.

VI. USING THE U-FORM COIL

Function: The **U-Form Coil** (7) can be shaped to perform any of the previous coils jobs, custom part removal, and Hail/Soft dent removal.

A. Loosening Corroded, Rusted and “Frozen” Nuts and Bolts $>3/4$ ”

Step 1 Perform the “Preparation for Use” instructions.

Step 2 Configure the coil to the size nut by wrapping it around a socket piece for that nut.

Tip: The more coil winds you can get the faster it will heat. (3-4 Wraps)

Step 3 Insert both ends of the U-Form coil into the electrodes and tighten thumb screws.

Step 4 Bring the U-form Coil around the frozen nut, initially for only four seconds, back it away, and try to remove the nut with a wrench or socket. If it is still seized, apply the U-Form Coil for another 3-6 seconds, and then try the wrench again. There is usually no reason to heat a nut to a red-hot condition in order to free it from the corrosion holding it to the bolt.

B. Heat Shrinking Hail / Soft Dents in Sheet Metal

Step 1 Perform the “Preparation for Use” instructions.

Step 2 Configure the Coil to look like the diagram on the right.

Step 3 Holding the U-form coil $\frac{1}{2}$ to 1 inch above a dent, move it in a small circular motion and gradually bring it closer to the dent, but keeping it around the outside of the crown of the dent. As soon as the dent shrinks, back the U-Form Coil away quickly and cool the treated dent



with a damp rag. If the dent sucks in, you are not heating the crown far enough around the outside.

Repeat the procedure until removed completely.

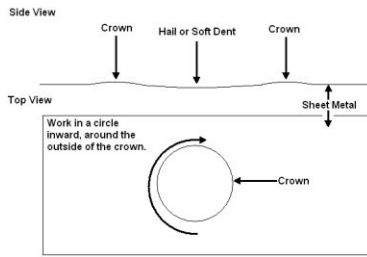

Tip: Also, be careful on white and light-colored finishes, these lighter paints tend to yellow sooner than darker colors.

this
been stretched too far.

Trouble Shooting: If the dent does not seem to want to shrink, may be because there is a crease in the metal, or the metal has

VII. USING THE BEARING BUDDY® COIL

Function: The **Bearing Buddy® Coil** (6) is used to free a race from an axle housing, frozen O² Sensors, remove ball joints, & tie-rod ends.

A. Expanding a piece to remove an interlocking part

Step 1 Perform the “Preparation for Use” instructions.

Step 2 Insert one end of the Bearing Buddy® Coil into one of the electrodes and tighten Twist-Lock.

Step 3 Wrap the coil at least 3 times around the work piece to be expanded.

Tip: The more coil windings you have the faster it will heat.

Step 4 Insert the other end into the remaining open electrode and tighten the Twist-Lock.

Step 5 Push the power switch to activate the Mini-Ductor® Venom® or Venom® HP.

Step 6 Heat until expanded enough to remove the race.

Step 7 Release the power switch and loosen Twist-Lock to remove the Bearing Buddy® Coil.

VIII. USING THE MINI-PAD (optional)

Function: The **Mini-Pad** (8) is used for removing stickers, decals, graphics, emblems, small body side moldings, and pin striping.

A. Removing Bonded on parts.

Step 1 Perform the “Preparation for Use” instructions.

Step 2 Insert both Mini-Pad ends into the electrodes and tighten Twist-Lock.

Step 3 Push the activation switch to activate the Mini-Ductor® Venom® or Venom® HP.

Step 4 Apply the Mini-pad in a back-and-forth motion to an end of the desired part to be removed to avoid overheating/burn marks for a couple seconds. Once you are able to peel the start of the part off, you will have an area you can pull on to keep outward pressures going. Re-apply the Mini-Pad to the part, working it down the part while keeping outward pressure until the part is completely removed.

IX. Trouble Shooting

The Mini-Ductor® Venom® and Venom® HP tool is designed with protection circuits that inhibit operation of the **inverter** (1) under specific conditions.

If the **activation switch** (9) is operated without a work coil attached or the coil is intermittently shorted or opened the **inverter** (1) will shut down and the **status indicator LED** (14) will turn Red.

Either of these faults will lock out inverter operation for approximately 3 seconds. The Red **status indicator LED** (14) will dim over the lock out time until it goes out.

If the tool's inverter electronics overheats, the tool will immediately shut down. The Red **status indicator LED** (14) will remain lit until the fan has cooled the electronics sufficiently to reset the thermal limit switch plus 3 seconds.

The tool is fully operational when the fan stops running.

Operation of the tool for extended periods or using too many turns on a **Bearing Buddy®** (6) or **U-Form** (7) coil can result in overheating.

This operation is independent of the **illumination LED** (White) (12). If the **illumination LED** (12) cannot be activated or the tool stops operating without a status indication, the tool has lost power.

Verify that the AC outlet power is functioning. If an extension cord is used with this tool, be sure it is appropriately rated and is not damaged.

The **status indicator LED** (14) will illuminate Red if the input voltage is too high. Care must be taken when using a generator to provide proper operating voltage.

If the problem does not correct itself or persists, call Induction Innovations®, Inc. at 877-688-9633.

Extension cord, if used, should be at least 14-AWG for a 25-foot cord or at least 12-AWG for a 50-foot cord.

Do not use more than one extension cord at a time.

X. Disassembly and Storage



Turn unit off and allow the unit and all working coils to cool for at least 30 minutes before disassembly, cleaning, or storage. Handling the unit or parts before they have cooled may result in injury; storage of unit while still hot may result in damage to equipment or pose a fire hazard.

Step 1 When you are finished working, turn the power OFF by releasing the **activation switch** (9) and make sure that the internal fan stops.

Step 2 Disconnect the **plug** (3) from the service outlet or extension cord.

Step 3 Place unit and coils into foam cutouts in storage case.

XI. Cleaning Instructions

A. Proper Cleaning Care

Step 1 Make sure unit is off and unplugged. Use a dry, clean, non-abrasive cloth or paper towel to remove grease, oil, and other dirt from the inverter, tools, and electrical cords before returning them to the storage case.

Step 2 For grease, oil, and dirt that is more difficult to remove, use generally available nonvolatile automotive interior cleaning products.

Allow all components to dry completely before using the Mini-Ductor® Venom® or Venom® HP.

B. Improper Cleaning Care

- Do NOT immerse any components of the unit in water or a cleaning solution.
- Do NOT spray the unit with a stream of water from a hose or wash any parts under a stream of water from a faucet, hydrant, or shower.
- Do NOT clean any components with volatile organic compounds such as gasoline, benzene, kerosene, methyl ethyl ketone (MEK), fuel oil, brake part cleaners, paint remover and thinners, varnish removers, plastic adhesive solvents, etc. These substances are fire hazards and will harden or dissolve

the polymer materials used in the Mini-Ductor® Venom® or Venom® HP components.

- Do NOT use heat guns, space heaters, torches, microwave, or gas ovens, etc. to dry the components of the Mini-Ductor® Venom® or Venom® HP after cleaning.

XII. WARRANTIES AND/OR REPAIRS

A. LIMITED WARRANTY

1. Induction Innovations® Inc. warrants the Inductor® Mini-Ductor® Venom® and Venom® HP and any parts thereof, to be free from defects in materials and workmanship for one year from the date of first purchase, excluding all work coils, when operated in accordance with the *Operating and Safety Instructions Manual*. This warranty is extended to the original purchaser when proof of purchase is provided. Induction Innovations® Inc. will cover ground transportation costs when returning a unit repaired under warranty within the United States. This warranty covers only the cost of parts and labor to restore the product to proper operating condition. Transportation and incidental costs associated with warranty repairs are not reimbursable under this warranty. Warranty service is available only through Induction Innovations® Inc. This warranty does not cover defects resulting from misuse, abuse, negligence, accidents, normal wear, alteration, modification, tampering, or repair by anyone other than the manufacture. This express warranty is given in lieu of any other warranty either expressed or implied, including warranties of merchantability and fitness for a particular use. Induction Innovations® Inc. assumes no responsibility for indirect, incidental, or consequential damages. Some states do not allow the exclusion or limitations of incidental or consequential damages or limitations, or exclusions may not apply to you. This Limited Warranty gives you specific legal rights and you may also have other rights which vary from state to state. Warranty is not valid unless the warranty card is returned within 30 days of the date of purchase. No unit will be warranted without proof of purchase. Shipping will be at the consumer's own expense. Return shipping will be at the factory's expense for units repaired under warranty. Return shipping will be via ground unless the consumer wishes to pay for faster service. Induction Innovations® Incorporated is not responsible for lost, stolen, or damaged unit(s) due to shipping. Warranty is non-transferable. When returning an Inductor® Mini-Ductor® Venom® and Venom® HP, all work coils and accessories must be returned with the unit to qualify it for warranty repair. Call **877-688-9633** for return authorization prior to shipment.

Warranty & Repair Service
Induction Innovations®, Inc.
1175 Jansen Farm Court
Elgin, IL 60123-2595

XIII. Definitions

- **Anneal:** [uh-neeel] ¹to heat metals to remove or prevent internal stress.
- **Ampere:** [am-peer, am-peer] ¹the base SI unit of electrical current, equivalent to one coulomb per second. *Abbreviation:* A, amp.
- **AWG:** ¹abbreviation for American Wire Gauge.
- **Capacitance:** [kuh-pas-i-tuh ns] ¹the property of being able to collect a charge of electricity. *Symbol:* C
- **Celsius:** [selsiəs] or centigrade, ¹ Of or relating to a temperature scale that registers the freezing point of water as 0° and the boiling point as 100° under normal atmospheric pressure.
- **Circuit:** [sur-kit] ¹ Also called electric circuit. the complete path of an electric current, including the generating apparatus, intervening resistors, or capacitors.
- **Concentrator®:** [kon-suh n-treyt] ¹a registered product name inductor used for removal of hail dents, frozen nuts, and other frozen or rusted hardware from cars.
- **Conductivity:** [kon-duhk-tiv-i-tee] ¹ Also called specific conductance. *Electricity.* a measure of the ability of a given substance to conduct electric current, equal to the reciprocal of the resistance of the substance. *Symbol:* σ
- **Current:** [kur-uh nt,] ¹the time rate of flow of electric charge, in the direction that a positive moving charge would take and having magnitude equal to the quantity of charge per unit time: measured in amperes.
- **Degree:** [di-gree] ¹a unit of measure, as of temperature or pressure.
- **Eddy Current:** [ed-ee kur-uh nt] ¹an electric current in a conducting material that results from induction by a moving or varying magnetic field.
- **Electromagnetic Interference:** [i-lek-troh-mag-net-ik in-ter-feer-uh ns] ¹Any electromagnetic disturbance that interrupts, obstructs, or otherwise degrades or limits the effective performance of electronics/electrical equipment. *abbreviation E.M.I.*
- **Fahrenheit:** [far-uh n-hahyt] ¹Of or relating to a temperature scale that registers the freezing point of water as 32° and the boiling point as 212° at one atmosphere of pressure
- **Farad:** [far-uh d] ¹the SI unit of capacitance, formally defined to be the capacitance of a capacitor between the plates of which there appears a potential difference of one volt when it is charged by a quantity of electricity equal to one coulomb. *Symbol:* F
- **Fast-Off®:** [fast awf] ¹a registered product name inductor used for removal of body side moldings, vinyl graphics, and other adhesive bonded parts to automobiles.
- **Ferrite:** [fer-ahyt] ¹ *chemistry* a compound, as NaFeO₂, formed when ferric oxide is combined with a more basic metallic oxide. ² *Metallurgy* the pure iron constituent of ferrous metals, as distinguished from the iron carbides
- **Ferrous:** [fer-uhs] ¹of or containing iron.
- **Flux:** [fluhks] ¹The lines of force of an electric or magnetic field.
- **Frequency:** [free-kwuh n-see] ¹the number of cycles or completed alternations per unit time of a wave or oscillation. *Symbol:* F; *Abbreviation:* freq.
- **G.F.I.:** *see Ground Fault Interrupter.*
- **Glass Blaster®:** [glaHS, glas] ¹a registered product name inductor used for removal of automotive glass and body panels. Can be an attachment or a single attachment hardwired unit.
- **Ground Fault Interrupter:** [ground fawlt in-tuh-ruh-ter] ¹a circuit breaker that senses currents caused by ground faults and rapidly shuts off power before damage can happen to equipment.
- **Henry:** [hen-ree] ¹ the SI unit of inductance, formally defined to be the inductance of a closed circuit in which an electromotive force of one volt is produced when the electric current in the circuit varies uniformly at a rate of one ampere per second. *Abbreviation:* H
- **Hertz:** [hurts] ¹ the SI unit of frequency, equal to one cycle per second. *Abbreviation:* Hz
- **Hysteresis:** [his-tuh-ree-sis] ¹the delay in response exhibited by a body in reacting to changes in the forces, esp. magnetic forces, affecting it.
- **HF:** (High Frequency [hī free-kwuh n-see]) ¹the range of frequencies in the radio spectrum between 3 and 30 megahertz.\
- **Inductance:** [in-duhk-tuh ns] ¹ that property of a circuit by which a change in current induces, by electromagnetic induction, an electromotive force. *Symbol:* L
- **Induction:** [in-duhk-shuh n] ¹the process by which a body having electric or magnetic properties produces magnetism, an electric charge, or an electromotive force in a neighboring body without contact.

- **Inductor:** [in-duhk-tor] ¹a coil used to introduce inductance into a ferrous work piece. ²(Inductor®) A registered brand name of the only patented induction heating system for the automotive aftermarket.
- **Inverter:** [in-vur-ter] ¹a device that converts direct current into alternating current.
- **Kilowatt:** [kil-uh-wot] ¹unit of power, equal to 1000 watts. *Abbreviation:* kW kw
- **Ohm:** [ohm] ¹ the SI unit of electrical resistance, defined to be the electrical resistance between two points of a conductor when a constant potential difference applied between these points produces in this conductor a current of one ampere. The resistance in ohms is numerically equal to the magnitude of the potential difference. *Symbol:* Ω
- **Resistance:**[ri-zis-tuh ns] ¹a property of a conductor by virtue of which the passage of current is opposed, causing electric energy to be transformed into heat.
- **Rosebud:** [roh-z-buhd] ¹a registered product name inductor used for annealing, warming of frame rail for straightening, etc.
- **Temper:** [tem-per] ¹ the degree of hardness and strength imparted to a metal, as by quenching, heat treatment, or cold working. ² the operation of tempering.
- **Volt:** [vohlt] ¹the SI unit of potential difference and electromotive force, formally defined to be the difference of electric potential between two points of a conductor carrying a constant current of one ampere, when the power dissipated between these points is equal to one watt. *Abbreviation:* V
- **Voltage:** [vohl-tij] ¹electromotive force or potential difference expressed in volts.
- **Watt:** [wot] ¹the SI unit of power, equivalent to one joule per second and equal to the power in a circuit in which a current of one ampere flows across a potential difference of one volt. *Abbreviation:* W, w.

My Mini-Ductor® Venom® or Venom® HP Dealer:

Company: _____

Contact: _____

Address: _____

City _____ State ____ Zip _____

Phone #: _____

Alt. Phone #: _____

Fax #: _____

Email: _____

Website: _____

My Mini-Ductor® Venom® or Venom® HP

Model: Mini-Ductor® Venom® or Venom® HP

Serial #: _____

Please do not forget to complete your product registration at www.theinductor.com!

Notes: