



**IMPORTANT: Read These Operating and Safety Instructions before Using the Mini-Ductor II+CE**

# MINI-DUCTOR® II+ CE

## OPERATING AND SAFETY INSTRUCTIONS

Specializing in High Performance Induction Heating Systems for the Automotive Aftermarket



# INDUCTION INNOVATIONS

Induction International, Inc.  
1175 Jansen Farm Court  
Elgin, IL 60123-2595  
[www.theINDUCTOR.com](http://www.theINDUCTOR.com)

Toll Free 877-688-9633  
Local 847-836-6933  
Fax 847-551-3369  
[info@theinductor.com](mailto:info@theinductor.com)

FORM 072015002

Mini-Ductor® II + CE Instruction Manual  
Copyright © 2015 by Induction International, Inc.

All rights reserved. No part of this document shall be reproduced, stored in a retrieval system or transmitted by any means, electronic, mechanical, chemical, optical, magnetic, photocopy, printing or otherwise, except by written permission of the author or Induction International. No patent liability is assumed with respect to the information contained herein.

Trademarks

Mini-Ductor® is a trade mark of Induction International Inc. All terms or service marks used in this manual have been appropriately capitalized. The company, Induction International Incorporated cannot attest to the accuracy of this information. Use of a trademark or service mark in this manual should not be regarded as affecting the validity of any trademark or service mark.

Warning and Disclaimer of Use:

Every effort has been made to insure the accuracy and completeness of this manual, but no warranty or fitness is implied. This information is provided on an as is bases. The authors and Induction International, Inc. shall have neither liability nor responsibility to any person or entity with respect to any loss or damages, direct or indirect, arising from use of the information contained in this document.

# Table of Contents

	Page
I. Safety Rules.....	4-7
A. General Work Area Safety Rules.....	4
B. Personal Safety Rules.....	4-5
C. Electrical Safety Rules.....	5-6
D. Fire Hazard Safety Rules.....	6
E. Tool Use Safety Rules.....	6-7
II. Inductor® Mini-Ductor II+ Components.....	8
III. Principles of Operation.....	9
IV. Preparation for Use.....	9
A. Generator & Inverter Use.....	9
1. Generator.....	9
2. Inverter.....	9
V. Using the Pre-Formed™ coil.....	9-10
A. Loosening Corroded, Rusted and “Frozen” Nuts and Bolts ≤3/4” ....	10
VI. Using the U-Form™ coil.....	10
A. Loosening Corroded, Rusted and “Frozen” Nuts and Bolts >3/4” ....	10
B. Heat Shrinking Hail / Soft Dents in Sheet Metal.....	10
VII. Using the Bearing Buddy™ coil.....	11
A. Expanding a piece to remove an interlocking part.....	11
VIII. Using the Mini-Pad™ (optional).....	11
A. Removing Bonded on parts.....	11
IX. Troubleshooting.....	11
X. Disassembly & Storage.....	11-12
XI. Cleaning Instructions.....	12
A. Proper Cleaning Care.....	12
B. Improper Cleaning Care.....	12
XII. Warranty & Repairs.....	12
A. Limited Warranty.....	12
Definitions.....	13-14
My Mini-Ductor II+ Dealer Information.....	15

This product is covered by patent numbers; 6,563,096 and 6,670,590

# I. Safety Rules for Using the Mini-Ductor<sup>®</sup> II+

## A. General Work Area Safety Rules

**⚠ WARNING**



**Read and understand all instructions.** Failure to follow all instructions listed below may result in electric shock, fire, and/or serious personal injury.

**⚠ WARNING**

**Keep your work area clean and well illuminated.** Cluttered and dark areas invite accidents.

**⚠ WARNING**

**Keep bystanders, children, visitors and animals away while operating the Mini-Ductor II+.** These beings may create distractions that cause you to lose control of the Mini-Ductor II+

**⚠ WARNING**

**Work outdoors, if there is no danger of rain, water or moisture.** If this is not possible, keep the inside work area well ventilated and dry. Be sure that ventilation fans are moving air from the inside to the outside.

**⚠ CAUTION**

**Keep a fully charged fire extinguisher at hand at all times when using the Mini-Ductor II+.**

## B. Personal Safety Rules

**⚠ DANGER**



**Do not operate the Mini-Ductor II+, and stay at least three feet away from an operating Mini-Ductor II+, if you have a cardiac pacemaker or any other kind of electronic or metal surgical implant.** Although the magnetic fields emanating from the tools travel only a few inches, they pose a dangerous risk to the proper operation of all implanted medical electronic devices in the user and any bystanders. Thus, it is necessary that people with electronic or metallic medical implants do NOT use the Mini-Ductor II+ or come within three feet of it when it is in use in case an accident should occur and the tool in use is inadvertently and unexpectedly brought near the person with the implant.



**⚠ WARNING**

**Do not operate the Mini-Ductor II+ while wearing any metallic items such as jewelry, rings, watches, chains, identification tags, religious medals, belt buckles, body piercing hardware, etc.** The Mini-Ductor II+ can heat these metallic objects very quickly and cause serious burns or even ignite clothing.



**⚠ WARNING**

**Do not operate the Mini-Ductor II+ while under the influence of drugs, alcohol or any medication.**

**⚠ WARNING**

**Do not overreach, keep proper footing and balance at all times.** Proper footing and balance enables better control of the Mini-Ductor II+ in unexpected situations.

**⚠ WARNING**

**Do not use the Mini-Ductor II+ within 4 inches of any airbag component.** The heat created from the Mini-Ductor II+ can ignite the air bag propellant, causing it to explode without warning. Refer to the vehicles service manual for precise airbag location before operating.

## Personal Safety Rules Continued

### WARNING



Remove all loose coins, metallic tokens, keys, chains, pocket knives, miniature tools, or any other metallic object in or on your clothing before operating the Mini-Ductor II+. Do not replace these items until you are finished using the Mini-Ductor II+. The Mini-Ductor II+ can heat these metallic objects very quickly and cause serious burns or even ignite clothing.

### WARNING



Do not wear clothing that is made with metallic pocket rivets, waist band buttons, pocket buttons, and zippers when operating the Mini-Ductor II+. The Mini-Ductor II+ can heat such metallic items very quickly and cause serious burns or even ignite clothing.

### WARNING



Always wear safety goggles when using the Mini-Ductor II+.

### WARNING



Fumes and smoke from hot/burning adhesives are toxic. Wear a dual filter (dust and fume) respirator mask which has been approved by the Occupational Safety and Health Administration (OSHA), the National Institute of Safety and Health (NIOSH), or the United States Bureau of Mines. These masks and replaceable filters are readily available at major hardware stores. Be sure the mask fits. Beards and facial hair may keep masks from sealing properly. Change filters often. DISPOSABLE PAPER MASKS ARE NOT ADEQUATE.

### WARNING



Wear heat-resistant gloves when using the Mini-Ductor II+. The Mini-Ductor II+ heats metal very quickly. You can burn your hands and fingers when trying to remove parts from hot metal surfaces.

### WARNING

The Mini-Ductor II+ is not to be used by children or persons with reduced physical, sensory or mental capabilities, or lack of experience and knowledge, unless they have been given supervision or instruction.

### WARNING

Children being supervised not to play with the Mini-Ductor II+

### C. Electrical Safety Rules

**⚠ DANGER**



Do not use the Mini-Ductor II+ in the rain, moisture or immerse in water. Exposing the Mini-Ductor II+ to water or other liquids may cause an electrical shock hazard.

**⚠ WARNING**



Do not abuse the electrical cord. Never use the cord to carry the Mini-Ductor II+. Keep the cord away from heat, oil, sharp edges and/or moving parts. Do not use the Mini-Ductor II+ if the cord is damaged. Cords cannot be repaired, only replaced. Damaged cords create electric shock hazards.

**⚠ WARNING**



Disconnect the Mini-Ductor II+ power supply cord from the outlet before changing any of the applicators.

**⚠ CAUTION**



Unplug the Mini-Ductor II+ from the power supply outlet or cord when not in use.

**⚠ CAUTION**



#### EXTENSION CORDS:

If an extension cord is necessary, only the following two cord lengths are authorized for use with the Mini-Ductor II+:

**25 foot, 14-AWG;  
50-ft, 12-AWG.**

- Use only one extension cord at any one time.
- Do not connect two or more extension cords in series with each other.
- Do not use any other extension cords except those specified above. Unwrap extension cords — tightly wrapped extension cords can overheat and cause fires.

### D. Fire Hazard Safety Rules

**⚠ DANGER**



Do not attempt to heat aerosol cans, paint cans, or any pressurized containers used for storing fuels, compressed gases, and liquids. The heat generated by the Mini-Ductor II+ can cause these containers to explode and their contents to ignite.

**⚠ CAUTION**



**Do not use any heating coil if insulation has been breached.** If insulation has been breached it will cause sparking when contacting with a vehicle. This will be a fire hazard especially when working on or near gas lines and/or gas tanks. Using coils with breached insulation will void warranty.

**E. Tool Use Safety Rules**

**⚠ WARNING**



**Do not leave the Mini-Ductor II+ unattended when it is ON.**

**⚠ WARNING**



**Make sure that the Power Unit has a sufficient supply of air for cooling.** Make sure that the vents of the Mini-Ductor II+ Power Unit are clean and free of dust and debris so that the Power Unit has an unimpeded flow of cooling air.

**⚠ CAUTION**

**Do not attempt to repair or service the Mini-Ductor II+.** There are no user-serviceable parts except for replacing the coil attachments.

**⚠ CAUTION**

**Before plugging in the Mini-Ductor II+, make sure that the outlet voltage supplied is compatible with the voltage marked on the nameplate within 10%.** An outlet voltage incompatible with that specified on the nameplate can result in serious hazards and damage to the Mini-Ductor II+.

**⚠ CAUTION**

**Do not twist or bend electrical cord sharply, or damage to internal wiring may result.**

**⚠ CAUTION**

**Do not use the Mini-Ductor II+ longer than the duty cycle.** The circuit board has an overheat protection device for protection, however the electrodes do not have overheat protection. Duty cycle: two minutes on two minutes off.

**⚠ CAUTION**

**If the supply cord is damaged, it must be replaced by the manufacture, its service agent or similarly qualified persons in order to avoid hazard.**

## II. Components

1. Inverter
2. Serial Plate (back)
3. Storage case (Not Shown)
4. Model
5. Cord & Plug 230 VAC
6. Vent (end)
7. Pre-Formed™ coil
8. Bearing Buddy™ coil
9. U-Form™ coil
10. Mini-Pad™ work coil (optional)
11. Owners Manual (Not Shown)
12. Activation Switch
13. Electrodes (top)
14. Thumb Screw
15. L.E.D.

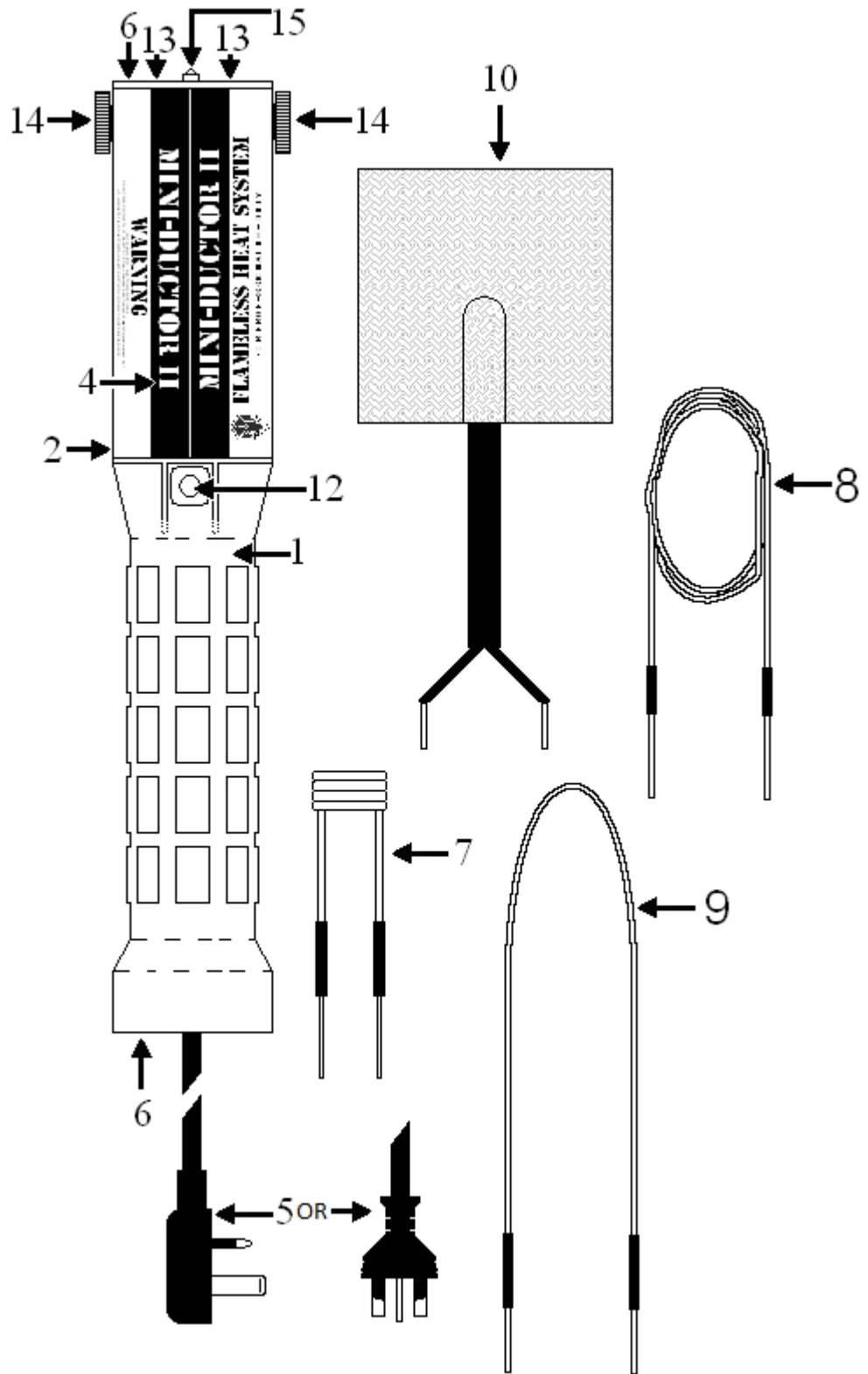



### III. PRINCIPLES OF OPERATION

The **power cord**, when connected to a GFI outlet, (11) insures a properly grounded 230 VAC power input connection. The **inverter** (1) steps up ordinary 230 volt, 50 Hz alternating line current. A work coil, the **Bearing Buddy™ coil** (8), **U-Form™ coil** (9), **Pre-Formed™ coil** (7), or **Mini-Pad™** (10), is inserted into the end of the **electrodes** (13) and then secured into place with the **thumb screws** (14). The coil then converts the current to a high frequency alternating magnetic field. This magnetic field crosses the metallic, conductive work surface (e. g., the frozen nut) and vibrates the electrons in the metal through the principle of electromagnetic induction. The kinetic energy of the moving electrons is dissipated as heat, which warms whatever metal is within the tool's working range. The more easily magnetized a substance is, the greater the heat developed in it. That is why the Mini-Ductor II+ heats ferrous metals and their alloys readily, but has no effect on glass, plastics, wood, cloth and other non-conductive materials. The **activation switch** (12) is used to turn the inverter on and off. Push it in to activate the inverter. The inverter will remain active as long as pressure is applied to the switch. Remove pressure from the switch to deactivate the inverter. Record the serial number from the **serial number plate** (2) on the inverter to the enclosed Warranty Card and mail.

### IV. PREPARATION FOR USE



Read and understand all safety warnings and cautions in this manual before operating the Mini-Ductor II+.

#### A. Generator & Inverter Use



The Mini-Ductor II+ is designed to operate from a normal 230 volt alternating current (VAC), 50 or 60 Hz (cycles per second) power line or service outlet, and will operate without suffering damage on voltages between 207 and 253.

1. Generator: Some portable generators, particularly low-cost units producing 4 kW or less, are unregulated and can produce in excess of 260 VAC which will damage the unit and void the warranty. If you are in doubt concerning the electrical generator that will be supplying power to the Mini-Ductor II+, have a professional electrical contractor measure the generator voltage with a digital voltmeter. Measure the voltage with the generator engine warm and no load. Some generators, the voltage may be reduced by decreasing the engine speed.
2. Inverter: DC to AC Inverter operation; Use only 1.8 kW or larger sine wave inverter. The use of square or quasi-sine wave inverter will void the warranty.

### V. Using the Pre-Formed™ coil

Function: The **Pre-Formed™ coil** (7) is used to heat nuts, fasteners, caulking removal, frozen door hinges, exhaust manifold bolts, truck under bed bolts, Sensors (O<sup>2</sup>) etc.



The life of the Pre-Formed™ coil can be extended by only heating objects enough to break the frozen rust bond. The insulation of the coil will eventually burn through when holding directly to hot nuts and may void warranty.

A. Loosening Corroded, Rusted and “Frozen” Nuts and Bolts  $\leq \frac{3}{4}$ ”

**Step 1** Perform the “Preparation for Use” instructions.

**Step 2** Push the activation switch to activate the Mini-Ductor II+.

**Step 3** Bring the Pre-Formed™ coil around the frozen nut, initially for only two seconds, back it away, and try to remove the nut with a wrench or socket. If it is still frozen, apply the Pre-Formed™ coil for another two seconds, and then try the wrench again. There is usually no reason to heat a nut to a red-hot condition in order to free it from the corrosion holding it to the bolt.

## VI. USING THE U-FORM™ COIL

Function: The U-Form™ coil can be shaped to perform any of the previous coils jobs, custom part removal, and Hail/Soft dent removal.

A. Loosening Corroded, Rusted and “Frozen” Nuts and Bolts  $>\frac{3}{4}$ ”

**Step 1** Perform the “Preparation for Use” instructions.

**Step 2** Configure the coil to the size nut by wrapping it around a socket piece for that nut.

**Tip:** *The more coil winds you can get the faster it will heat.*

**Step 3** Insert both ends of the U-Form™ coil into the electrodes and tighten thumb screws.

**Step 4** Bring the U-Form™ coil around the frozen nut, initially for only two seconds, back it away, and try to remove the nut with a wrench or socket. If it is still frozen, apply the U-Form™ coil for another two seconds, and then try the wrench again. There is usually no reason to heat a nut to a red-hot condition in order to free it from the corrosion holding it to the bolt.

B. Heat Shrinking Hail / Soft Dents in Sheet Metal

**Step 1** Perform the “Preparation for Use” instructions.

**Step 2** Configure the Coil to look like the diagram on the right.

**Step 3** Holding the U-Form™ coil  $\frac{1}{2}$  to 1 inch above a dent, move it in a small circular motion and gradually bring it closer to the dent, but keeping it around the outside of the crown of the dent. As soon as the dent shrinks, back the U-Form™ coil away quickly and cool the treated dent with a damp rag. If the dent sucks in you are heating the crown or not far enough around the outside of the crown. Repeat the procedure until removed completely.

**Tip:** *Once a puff of smoke releases from the dent immediately remove the U-Form™ coil from the area. This is the point at which the paint will start to bubble. Also be careful on white and light colored finishes, these lighter paints tend to yellow sooner than darker colors.*

**Trouble Shooting:** If the dent doesn't seem to want to shrink, this may be because there is a crease in the metal or the metal has been stretched to far.

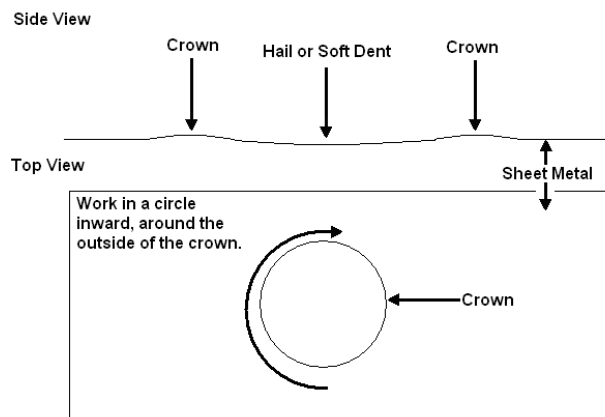

## VII. USING THE BEARING BUDDY™ COIL

Function: The **Bearing Buddy™ coil** (8) is used to free a race from an axle housing, frozen O<sup>2</sup> Sensors, remove ball joints, & tie-roc ends.

### A. Expanding a piece to remove an interlocking part

**Step 1** Perform the “Preparation for Use” instructions.

**Step 2** Insert one end of the Bearing Buddy™ coil into one of the electrodes and tighten thumb screw.

**Step 3** Wrap the coil at least 3 times around the work piece to be expanded.

*Tip: The more coil winds you have the faster it will heat.*

**Step 4** Insert the other end into the remaining open electrode and tighten the thumb screw.

**Step 5** Push the activation switch to activate the Mini-Ductor II+.

**Step 6** Heat until expanded enough to remove the race.

**Step 7** Release the power switch and loosen both thumbscrews to remove the Bearing Buddy™ coil.

## VIII. USING THE MINI-PAD™ (optional)

Function: The Mini-Pad™ (10) is used for removing stickers, decals, graphics, emblems, small body side moldings, and pin striping.

### A. Removing Bonded on parts.

**Step 1** Perform the “Preparation for Use” instructions.

**Step 2** Insert both Mini-Pad™ ends into the electrodes and tighten thumb screws.

**Step 3** Push the activation switch to activate the Mini-Ductor II+.

**Step 4** Apply the Mini-Pad™ to the end of the desired part to be removed for a couple seconds. Once you are able to peel the start of the part off, you will have an area you can pull on to keep outward pressures going. Re-apply the Mini-Pad™ to the part, working it down the part while keeping outward pressure until the part is completely removed.

## IX. Trouble Shooting

1. The Mini-Ductor II+ inverter is designed to stop running if overheated, however, the electrodes DO NOT have an overheat shutoff. This is why there is a duty cycle with the Mini Ductor. Two minutes on two minutes off. If the unit stops suddenly: check to insure unit is still plugged into a functioning AC power outlet. Also be sure if using an extension cord that there are no cuts in the cord. Allow the unit to cool off for at least 30 minutes and then restart. If problems persist call your dealer.
2. If there is a lack of power output, this may be from using an improper extension cord or a damaged attachment. The proper gauge and length cord is 25 ft., 14-AWG or 50-ft, 12-AWG. Do not use more than one extension cord at once.
3. For other problems contact your dealer.

## X. Disassembly and Storage

**⚠ CAUTION**



Turn unit off and allow the unit and all working coils to cool for at least 30 minutes before disassembly, cleaning or storage. Handling the unit or parts before they have cooled may result in injury; storage of unit while still hot may result in damage to equipment or pose a fire hazard.

**Step 1** When you are finished working, turn the power OFF by releasing the power switch and make sure that the internal fan stops.

**Step 2** Disconnect the plug (11) from the service outlet or extension cord.

**Step 3** Place unit and coils into foam cutouts in storage case.

## XI. Cleaning Instructions

### A. Proper Cleaning Care

**Step 1** Make sure unit is off and unplugged. Use a dry, clean, non-abrasive cloth or paper towel to remove grease, oil, and other dirt from the inverter, tools, and electrical cords before returning them to the storage case.

**Step 2** For grease, oil and dirt that is more difficult to remove use generally available nonvolatile automotive interior cleaning products.

Allow all components to dry completely before using the Mini-Ductor II+.

### B. Improper Cleaning Care

- Do NOT immerse any components of the unit in water or a cleaning solution.
- Do NOT spray the unit with a stream of water from a hose, or wash any parts under a stream of water from a faucet, hydrant or shower.
- Do NOT clean any components with volatile organic compounds such as gasoline, benzene, kerosene, methyl ethyl ketone (MEK), fuel oil, brake part cleaners, paint remover and thinners, varnish removers, plastic adhesive solvents, etc. These substances are fire hazards and will harden or dissolve the polymer materials used in the Mini-Ductor II+ components.
- Do NOT use heat guns, space heaters, torches, microwave or gas ovens, etc. to dry the components of the Mini-Ductor II+ after cleaning.

## XII. WARRANTIES AND/OR REPAIRS

### A. LIMITED WARRANTY

1. Induction International Inc. warrants the Inductor® Mini-Ductor II+ and any parts thereof, to be free from defects in materials and workmanship for one year from the date of first purchase, excluding all work coils, when operated in accordance with the *Operating and Safety Instructions Manual*. This warranty is extended to the original purchaser, when proof of purchase is provided. Induction International Inc. will cover ground transportation costs when returning a unit repaired under warranty. This warranty covers only the cost of parts and labor to restore the product to proper operating condition. Transportation and incidental costs associated with warranty repairs are not reimbursable under this warranty. Warranty service is available only through Induction International Inc. This warranty does not cover defects resulting from misuse, abuse, negligence, accidents, normal wear, alteration, modification, tampering, or repair by anyone other than the manufacture. This express warranty is given in lieu of any other warranty either expressed or implied, including warranties of merchantability and fitness for a particular use. Induction International Inc. assumes no responsibility for indirect, incidental or consequential damages. Some states do not allow the exclusion or limitations of incidental or consequential damages or limitations or exclusions may not apply to you. This Limited Warranty gives you specific legal rights and you may also have other rights which vary from state to state. Warranty is not valid unless the warranty card is returned within 30 days of the date of purchase. No unit will be warranted without proof of purchase. Shipping will be at the consumer's own expense. Return shipping will be at the factory's expense for units repaired under warranty. Return shipping will be via ground, unless the consumer wishes to pay for faster service. Induction International Incorporated is not responsible for lost, stolen, or damaged unit(s) due to shipping. Warranty is non-transferable. When returning an Inductor® Mini-Ductor II+, all work coils and accessories must be returned with the unit to qualify it for warranty repair. Call your distributor for return authorization prior to shipment.

# Definitions

- **Anneal:** [uh-neeel] <sup>1</sup>to heat metals to remove or prevent internal stress.
- **Ampere:** [am-peer, am-peer] <sup>1</sup>the base SI unit of electrical current, equivalent to one coulomb per second. *Abbreviation:* A, amp.
- **AWG:** <sup>1</sup>abbreviation for American Wire Gauge.
- **Capacitance:** [kuh-pas-i-tuhns] <sup>1</sup>the property of being able to collect a charge of electricity. *Symbol:* C
- **Celsius:** [selsiəs] or centigrade, <sup>1</sup> Of or relating to a temperature scale that registers the freezing point of water as 0° and the boiling point as 100° under normal atmospheric pressure.
- **Circuit:** [sur-kit] <sup>1</sup> Also called electric circuit. the complete path of an electric current, including the generating apparatus, intervening resistors, or capacitors.
- **Concentrator®:** [kon-suh n-treyt-or] <sup>1</sup>a registered product name inductor used for removal of hail dents, frozen nuts, and other frozen or rusted hardware from cars.
- **Conductivity:** [kon-duhk-tiv-i-tee] <sup>1</sup> Also called specific conductance. *Electricity.* a measure of the ability of a given substance to conduct electric current, equal to the reciprocal of the resistance of the substance. *Symbol:*  $\sigma$
- **Current:** [kur-uhnt,] <sup>1</sup>the time rate of flow of electric charge, in the direction that a positive moving charge would take and having magnitude equal to the quantity of charge per unit time: measured in amperes.
- **Degree:** [di-gree] <sup>1</sup>a unit of measure, as of temperature or pressure.
- **Eddy Current:** [ed-ee kur-uhnt] <sup>1</sup>an electric current in a conducting material that results from induction by a moving or varying magnetic field.
- **Electromagnetic Interference:** [i-lek-troh-mag-net-ik in-ter-feer-uhns] <sup>1</sup>Any electromagnetic disturbance that interrupts, obstructs, or otherwise degrades or limits the effective performance of electronics/electrical equipment. *abbreviation E.M.I.*
- **Fahrenheit:** [far-uhn-hahyt] <sup>1</sup>Of or relating to a temperature scale that registers the freezing point of water as 32° and the boiling point as 212° at one atmosphere of pressure
- **Farad:** [far-uhd] <sup>1</sup>the SI unit of capacitance, formally defined to be the capacitance of a capacitor between the plates of which there appears a potential difference of one volt when it is charged by a quantity of electricity equal to one coulomb. *Symbol:* F
- **Fast-Off®:** [fast awf] <sup>1</sup>a registered product name inductor used for removal of body side moldings, vinyl graphics, and other adhesive bonded parts to automobiles.
- **Ferrite:** [fer-ahyt] <sup>1</sup> *chemistry* a compound, as NaFeO<sub>2</sub>, formed when ferric oxide is combined with a more basic metallic oxide. <sup>2</sup> *Metallurgy* the pure iron constituent of ferrous metals, as distinguished from the iron carbides
- **Ferrous:** [fer-uhs] <sup>1</sup>of or containing iron.
- **Flux:** [fluhks] <sup>1</sup>The lines of force of an electric or magnetic field.
- **Frequency:** [ free-kwuh n-see] <sup>1</sup>the number of cycles or completed alternations per unit time of a wave or oscillation. *Symbol:* F; *Abbreviation:* freq.
- **G.F.I.:** see *Ground Fault Interrupter.*

- **Glass Blaster®:** [glahs, glas] <sup>1</sup>a registered product name inductor used for removal of automotive glass and body panels. Can be an attachment or a single attachment hardwired unit.
- **Ground Fault Interrupter:** [ground fawlt in-*tuh*-ruh-p-ter] <sup>1</sup>a circuit breaker that senses currents caused by ground faults and rapidly shuts off power before damage can happen to generating equipment.
- **Henry:** [hen-ree] <sup>1</sup> the SI unit of inductance, formally defined to be the inductance of a closed circuit in which an electromotive force of one volt is produced when the electric current in the circuit varies uniformly at a rate of one ampere per second. *Abbreviation:* H
- **Hertz:** [hurts] <sup>1</sup> the SI unit of frequency, equal to one cycle per second. *Abbreviation:* Hz
- **Hysteresis:** [his-*tuh*-ree-sis] <sup>1</sup>the delay in response exhibited by a body in reacting to changes in the forces, esp. magnetic forces, affecting it.
- **HF:** (High Frequency [hī free-*kwuh*n-see]) <sup>1</sup>the range of frequencies in the radio spectrum between 3 and 30 megahertz.\
- **Inductance:** [in-duhk-*tuh*ns] <sup>1</sup> that property of a circuit by which a change in current induces, by electromagnetic induction, an electromotive force. *Symbol:* L
- **Induction:** [in-duhk-*shuh*n] <sup>1</sup>the process by which a body having electric or magnetic properties produces magnetism, an electric charge, or an electromotive force in a neighboring body without contact.
- **Inductor:** [in-duhk-tor] <sup>1</sup>a coil used to introduce inductance into a ferrous work piece. <sup>2</sup>(Inductor®) A registered brand name of the only patented induction heating system for the automotive aftermarket.
- **Inverter:** [in-vur-ter] <sup>1</sup>a device that converts direct current into alternating current.
- **Kilowatt:**[kil-*uh*-wot] <sup>1</sup>unit of power, equal to 1000 watts. *Abbreviation:* kW  
kw
- **Ohm:** [ohm] <sup>1</sup> the SI unit of electrical resistance, defined to be the electrical resistance between two points of a conductor when a constant potential difference applied between these points produces in this conductor a current of one ampere. The resistance in ohms is numerically equal to the magnitude of the potential difference. *Symbol:* Ω
- **Resistance:**[ri-zis-*tuh*ns] <sup>1</sup>a property of a conductor by virtue of which the passage of current is opposed, causing electric energy to be transformed into heat.
- **Rosebud™:**[ roh-z-buhd] <sup>1</sup>a trademarked product name, inductor used for annealing, warming of frame rail for straightening, etc.
- **Temper:**[ tem-per] <sup>1</sup> the degree of hardness and strength imparted to a metal, as by quenching, heat treatment, or cold working. <sup>2</sup> the operation of tempering.
- **Volt:** [vohlt] <sup>1</sup>the SI unit of potential difference and electromotive force, formally defined to be the difference of electric potential between two points of a conductor carrying a constant current of one ampere, when the power dissipated between these points is equal to one watt. *Abbreviation:* V
- **Voltage:** [vohl-tij] <sup>1</sup>electromotive force or potential difference expressed in volts.
- **Watt:** [wot] <sup>1</sup>the SI unit of power, equivalent to one joule per second and equal to the power in a circuit in which a current of one ampere flows across a potential difference of one volt. *Abbreviation:* W, w.

## MY MINI-DUCTOR II+ DEALER:

Company: \_\_\_\_\_

Contact: \_\_\_\_\_

Address: \_\_\_\_\_

City \_\_\_\_\_ Country \_\_\_\_\_ Postal \_\_\_\_\_

Phone #: \_\_\_\_\_

Alt. Phone #: \_\_\_\_\_

Fax #: \_\_\_\_\_

Email: \_\_\_\_\_

Website: \_\_\_\_\_

My Mini-Ductor II+

Model: Mini-Ductor II+ CE

Serial #: \_\_\_\_\_

Notes: